

Mini Inverter Series



STANDARD		OPTIONAL	

DESCRIPTION

- Mini-electrical inverter systems for powering up to 220W/250VA of incandescent, fluorescent, induction or LED lighting loads. Pulse width modulated (PWM) output design provides clean, 60 Hz. sinusoidal emergency power to loads.
- Models are available for surface, recessed or T-Grid mounting as required.

ELECTRICAL SPECIFICATIONS

Input

- Input Voltages: 120 or 277VAC $\pm 10\%$
- Input Frequencies: 60Hz $\pm 2\%$
- Input Protection: AC Line Fuses

Output

- Output Voltages: (60Hz) 120 or 277VAC
- Efficiency Rating: 98% at full rated load (line)
- Waveform: Sinusoidal (digitally controlled)
- Static Voltage: $\pm 5\%$ during battery discharge. 0-100% linear load.
- Output Frequencies: 60Hz. $\pm 0.3\text{Hz}$ during emergency cycle
- Output Distortion: Less than 3% THD (linear load)
- Transfer Time: Less than 1.0 second
- Load Power Factor Range: 0.44 Lead to 0.44 Lag
- Minimum Loading: 0% of rated system capacity
- Output Protection: Line and inverter fuses

HOUSING

- Heavy duty steel cabinet is finished in white baked-on powder paint providing scratch and corrosion resistance.

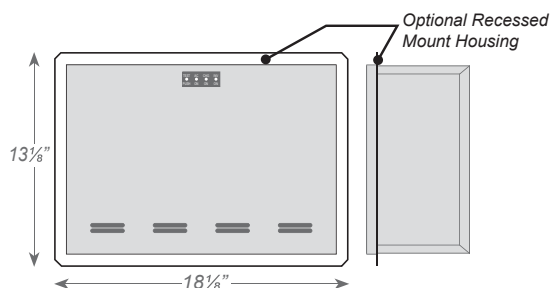

MOUNTING

- Surface Mount (Standard Models):** Surface mount models are designed for mounting to walls by means of keyhole slots provided in the back of the unit housing.
- Recess Mount (EMPS55125, EMPS110125 Only):** Recess models provide recess mounting holes on both sides of the enclosure.
- T-Grid Mount (EMPS55125, EMPS110125 Only):** Housing design allows simple drop-in installation between T-grid runs. Safety wires (supplied by others) are required for attachment to building structure.

WARRANTY / LISTING

- Unit:** (excluding lamps) Full coverage against defects in materials and workmanship for 3 years from date of shipment.
- Battery:** 3 years full warranty plus an additional 7 years of pro-rata coverage.
- All models are UL924 Listed and meet NFPA 101 Life Safety Code, NEC, OSHA, Local and State Codes. Optional T-Grid models are plenum rated, to UL2043 and meets city of Chicago CCEA Requirements.
- UL Listed for damp locations (20° - 30°C).
- Optional C models are Certified to CEC Under Title 20 regulations
- FCC Part 15 Class B Compliant.

DIMENSIONS

Standard Surface Mount Housings

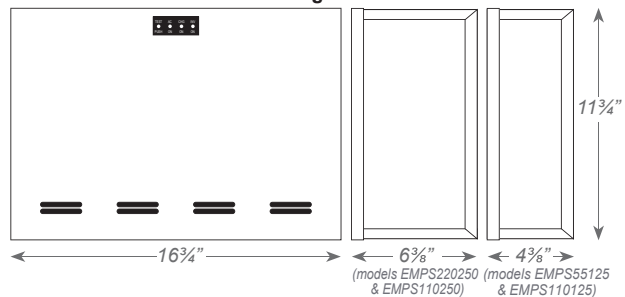

Optional Ceiling T-grid Mount Housing

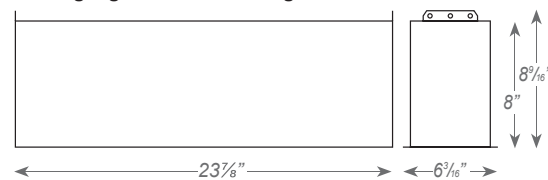

Mini Inverter Series



The Mini Inverter Series is designed to provide up to 220W/250VA of emergency power to incandescent, fluorescent, induction and/or LED fixtures. The Mini Inverter Unit provides clean, sinusoidal AC output power allowing it to be remotely mounted up to 1,000 feet away from the controlled fixture(s).

Unlike a ballast fluorescent emergency pack, the Mini Inverter provides power to the input side of the fixture, (including the ballast) eliminating any chance of incompatibility. The Mini Inverter Series is designed primarily for surface mounting, however, the EMPS55125 and EMPS110125 models provide optional housings for recessed or ceiling T-Grid mounting if required. All Mini Inverter systems will provide emergency power output for a minimum of 90-minutes.

FEATURES

- For powering incandescent, fluorescent, induction and LED fixtures *
- Sinusoidal output eliminates compatibility problems
- Universal 120/277VAC, 60Hz. input/output
- Unit capacities up to 220W/250VA
- "Soft Start" design reduces fixture inrush current
- Unit may be installed up to 1,000 feet from controlled fixture(s)
- Surface, recessed or T-Grid mount models
- Lumen output from fixture is 100% of nominal
- Unique design eliminates compatibility problems with LED drivers as well as fluorescent and induction ballasts
- Compatible with dimming ballasts
- Normally-ON and/or Normally-OFF load output
- Provisions for local switching capability - Always on during emergency conditions regardless of local switch position
- Emergency fixtures can be ON, OFF or SWITCHED
- Solid-state, line latched low voltage disconnect provides protection against battery deep discharge
- Long life, maintenance-free lead-calcium battery
- Momentary test switch
- AC-ON, Charge-ON and Inverter-ON LED indicators

* Consult factory for compatibility for other lamp types

WIRING

Connection to an unswitched AC circuit is required by the NEC. Wiring access is provided for by conduit knockouts in the unit housing. EMPS55125 and EMPS110125 models also provide knockouts in the back of the housing for rear wiring from standard electrical boxes when surface mounting.

LOAD COMPATIBILITY

Mini Inverter model's clean, sinusoidal AC output will operate incandescent lamps as well as all common fluorescent, induction and LED lamp types. Consult factory for compatibility with all other lamp types.

Lighting loads are driven at 100% output for the entire emergency power cycle. This outstanding feature translates into greater occupant egress vision and safety.

SYSTEM OPTIONS ^{(1) (2)}

ADD SUFFIX	DESCRIPTION
S	Surface Mount Housing
R	Recess Mount Housing ⁽³⁾
T	Plenum Rated Ceiling T-Grid Mount Housing ⁽³⁾
4C	4 Output Circuit Switching ⁽⁴⁾
RTS	Remote Test Switch Panel ⁽⁴⁾
AO	Adjustable Output/Dimmer Bypass ⁽⁴⁾
SDT	Self-Testing / Self-Diagnostics ⁽⁴⁾
C	Title 20 Compliant

⁽¹⁾ Other options available. Consult factory.

⁽²⁾ Some options may impact product UL listing. Consult factory.

⁽³⁾ Available with EMPS55125 and EMPS110125 models only.

⁽⁴⁾ For more information, separate specification sheets are available on the 4C, RTS, SDT and AO options. Consult factory.

GENERAL SPECIFICATIONS

MODEL NUMBER	INPUT / OUTPUT VOLTS	CAPACITY for 1½ Hrs.		SYSTEM WEIGHT*		ON-LINE SYSTEM EFFICIENCY (full load)	NUMBER of BATTERIES	BATTERY VOLTAGE (VDC)	BATTERY CURRENT (amps)	AC INPUT CURRENT		THERMAL OUTPUT in BTUs	
		WATTS	VA	Lbs.	Kg.					120VAC (max)	277VAC (max)	ON-LINE	EMERGENCY
EMPS155125	120/277	55	125	30.0	14	98%	2	24	3.4	1.2	0.52	9	90
EMPS110125	120/277	110	125	42.0	17	98%	2	24	5.7	1.2	0.52	9	95
EMPS110250	120/277	110	250	45.2	21	98%	4	48	3.3	2.4	1.10	18	163
EMPS220250	120/277	220	250	60.0	27	98%	4	48	5.6	2.4	1.10	18	167

* System weights shown include installed batteries

Mini Inverter Series

BATTERIES AND CHARGER

Battery

Battery: Sealed Lead Calcium (10 year life)

Battery Voltage: 24VDC for EMPS55125, EMPS110125 models and 48VDC for EMPS110250, EMPS220250 models

Runtime: 90-minutes standard - based on battery performance at (25°C). Other runtimes available, consult factory.

Battery Protection: Low Voltage Battery Disconnect protects the battery from being severely damaged by deep discharge during prolonged power failures.

DC Overload and Short Circuit Protection provided by a DC input breaker and fuse.

Charger

Charger Type: Fully automatic, temperature compensated, dual-mode charger

Power Consumption (Charger Only):

15W maximum (2.5W in standby) for EMPS55125, and EMPS110125 models

30W maximum (5W in standby) for EMPS110250, and EMPS220250 models

Recharge Duty Cycle: Meets UL924 requirements

Battery Circuit Breaker: Also used as battery isolator

Controls: Momentary test switch, AC-ON,

Charge-ON and Inverter-ON LED indicator lights

Safety Circuitry: AC Lockout prevents battery discharge prior to initial unit power-up.

Brownout Protection automatically switches the unit to emergency mode when utility voltage is significantly reduced.

Environmental

Altitude: < 10,000 feet (3,000m) above sea level without derating.

Operating Temperature Range: 20°C to 30°C

NOTE: Optimum system performance between 20°C and 30°C; temperatures outside of this range will affect battery performance and life.

Relative Humidity: 95% non-condensing

OPERATION

Upon failure of the normal utility power the Mini Inverter unit is automatically turned on by a solid-state switching circuit and provides a minimum of 90-minutes of emergency power to the connected load. Lumen output will be maintained at 100% of the lamp's rating throughout the entire duration.

A solid-state low voltage disconnect circuit is used to protect the battery from being severely damaged by a deep discharge. When normal utility power is restored, the unit switches the load back to normal utility operation and the fully automatic, temperature compensated, dual mode charger begins to restore the battery; bringing it to full charge within UL924 specified parameters. A brownout sensing circuit insures proper operation during "low line" conditions.

SYSTEM STATUS MONITORING PANEL



All Mini Inverter Systems provide a monitoring panel on the front of the unit to show operating status at all times. The panel provides a test switch for user initiated system tests and a 3-LED array that provides an intuitive visual indication of unit readiness.

IMPROVED AESTHETICS

The Mini Inverter System's sinusoidal AC output design eliminates voltage drop and proximity concerns. This allows added flexibility in installation location as Mini Inverter units can be installed hundreds of feet from the units they power. This means Mini Inverter units can be located conveniently out of sight in closets or utility rooms without interrupting architectural aesthetics.

In lighting applications, no special or additional emergency fixtures are necessary. Simply designate and connect existing lighting fixtures, either interior or exterior, to the Mini Inverter unit for emergency operation eliminating the need for exposed, stand-alone emergency luminaires.

MINI INVERTER SYSTEM ADVANTAGES

Compared to traditional discrete emergency lighting units, the Mini Inverter Series provides emergency illumination from a single power source resulting in lower maintenance overhead and routine testing expenses.

Mini Inverter units lower installation costs by powering existing lighting fixtures during emergencies. And because connected fixtures are driven at full brilliancy, they provide far superior egress lighting and deliver improved occupant safety.

Mini Inverter Series

SUGGESTED SPECIFICATIONS

An inverter system with sinusoidal output shall be supplied capable of powering any combination of lighting fixtures, including incandescent, fluorescent, induction and/or LED light sources without compatibility problems.

The system shall transfer in less than 1.0 second to reliably back up lighting fixtures without loss of illumination and operate any and all connected lighting fixtures at full lumen output during the complete 90-minute discharge cycle.

The input voltage shall be the same as the output voltage and shall be single phase 120/277 volts, 60 Hz. Output capacity will be (55W/125VA) / (110 Watts/125VA) / (110 Watts/250VA) / (220 Watts/250VA) for a minimum duration of 90-minutes.

The design shall be a standby, off-line inverter with on-line efficiency of 98%; on-line double conversion UPS systems shall not be considered acceptable alternatives. Mini Inverter System output shall be a PWM generated sine wave with less than 3% total harmonic distortion with "Soft-Start" design reducing fixture inrush current. The system shall also provide short circuit and overload protection as standard.

An intuitive three LED display shall provide system operational information at a glance and alert user to any malfunction in system performance. Authorized maintenance personnel shall have access to the system's controls while being protected from any live exposed connections.

Protective devices shall include AC Line fuses, DC input breaker and a DC input fuse. The entire Mini Inverter system, including batteries, shall be incorporated into compact cabinetry which shall have provisions for (surface, recessed or T-Grid) mounting.

System shall be capable of providing up to 4 switch bypass circuits, adjustable output or 0 to10 volt dimmer bypass, remote test switch, and self-test/self-diagnostics, were necessary

System shall utilize a sealed lead calcium battery with a 10 year design life. The charger shall be temperature compensated, dual mode type, and recharge the batteries as per UL924 guidelines. Entire system shall be tested, approved, and labeled to UL924 Emergency Lighting and Power Systems standards. T-Grid models will be plenum rated.

WIRING DIAGRAMS

120VAC Connections

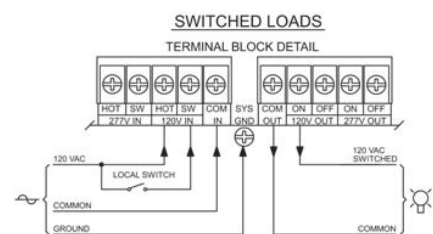
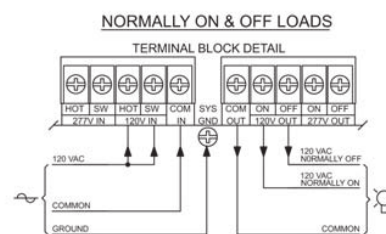
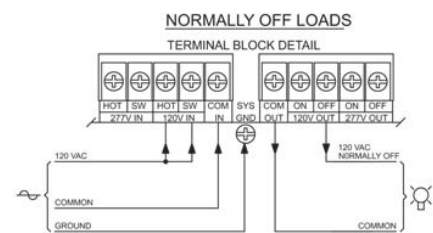
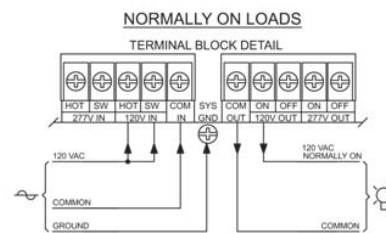

277VAC Connections

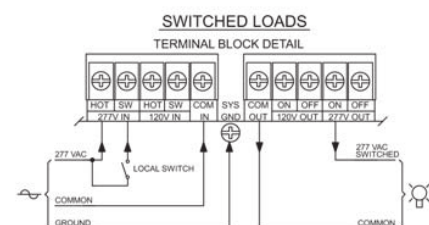
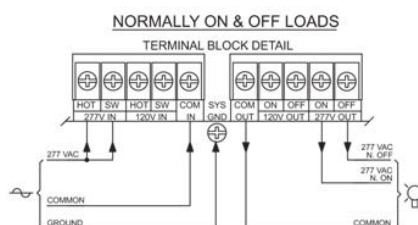
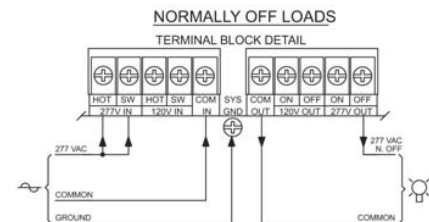
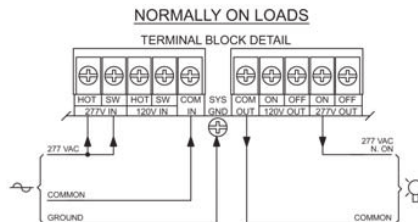

Micro, Mini, and Midsize Inverter Series

STANDARD



DESCRIPTION

RIB® Lighting Controls offers the self-testing and self-diagnostic (SDT) options in their Micro, Mini, and Midsize series of inverters. This feature is becoming increasingly more important to architects, engineers and building owners as they become more aware of its tremendous value-added functions and safety-assuring technology. UL Listed to meet NFPA 101 for self-testing and self-diagnostic requirements.

SELF-DIAGNOSTIC FUNCTIONS

The self-diagnostic function is factory preset and performs the following:

- Monitoring of battery, battery charger and connected loads.
- Self-testing and a 30-second battery discharge once every 30 days after normal utility power has been supplied for a minimum of 48 hours.
- Self-testing and a 30-minute battery discharge once every 180 days after normal utility power has been supplied for a minimum of 48 hours.
- Self-testing and a 90-minute battery discharge once every 365 days after normal utility power has been supplied for a minimum of 48 hours.

SERVICE INDICATION

LED INDICATOR	STATUS
GREEN Steady	Normal Service
RED/GREEN Blinking	High Charge Enabled
GREEN Blinking	Test mode Enabled
One Blink RED / Pause	Battery Charger Fault
Two Blinks RED / Pause	Battery Fault
Four Blinks RED / Pause	Lamp / Load Fault

MANUAL TESTING

ACTION	REACTION & LED INDICATION
Push test switch once (within 2 seconds)	30 Second test: One blink GREEN / Pause
Push test switch twice (within 2 seconds)	30 Minute test: Two blinks GREEN / Pause
Push test switch thrice (within 2 seconds)	90 Minute test: Three blinks GREEN / Pause
Push test switch and hold for 3 seconds	Cancels test
Push test switch and hold for 6 seconds	System reset

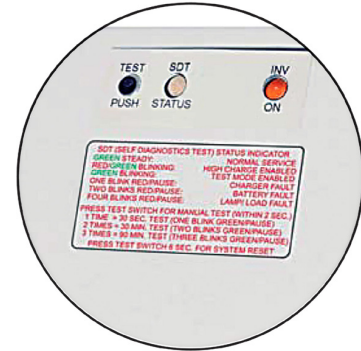

Improved Self-Diagnostic Feature

Mini Inverters



Micro Inverters



Midsize Inverters

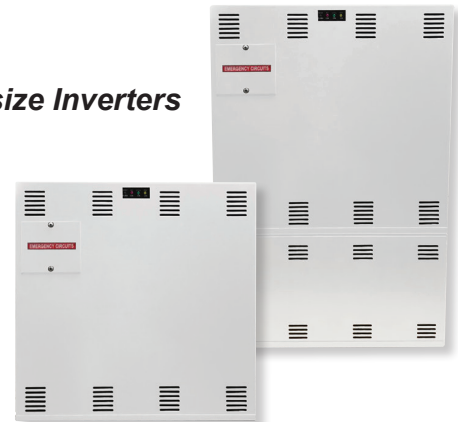

Mini and Midsize Inverter Emergency Power Systems

4C Option

Provides adjusted power output to connected LED loads during emergency mode operation regardless of local control switch position or operating status

Features

- Provides capacity for four override control circuits
- Provides full power emergency output to connected loads regardless of local control switch position or operating status
- Works with most standard local control devices including wall switches, dimmers, timers, occupancy sensors and ambient light sensors.
- Ideal for use with incandescent, fluorescent or LED lighting fixtures
- Eliminates the need for bypass devices or separate inverters for each switched load providing cost efficiency
- All wiring is done within the Mini and Midsize Inverter housing, no need for additional j-boxes
- Allows normally-on, normally-off, combination and switched wiring of connected loads
- System may be remotely mounted up to 1,000 feet
- Models available from 55 to 600 watt capacity

4C Option Operation

The inverter power system's 4C option allows lighting fixtures or other load types on circuits controlled by local switching devices to be easily connected to and powered by the Mini and Midsize Inverter system during utility power outages. The 4C option provides four local switching device override circuits which, under emergency mode operating conditions, automatically disconnect the load side of the local control device(s) and connect the selected loads to the inverter output assuring normal operation of connected loads regardless of local control device switch position or operating status.

4C Option Connectivity

Any or all of the 4C option override circuits may be used to power lighting fixtures or other loads, up to the maximum output capacity of the system. The outstanding features of the Mini and Midsize Inverter systems provide additional connectivity and flexibility features to the 4C option. The system's universal output allows for the powering of 120VAC and/or 277VAC loads and because the system's output is a clean, sinusoidal waveform, load compatibility issues are never a problem. Additionally, provisions are provided so that emergency loads can be configured for normally-on, normally-off, combination along with switched operation.

Mini Inverters



Midsize Inverters



All Mini and Midsize Series inverters offer:

- Universal 120/277VAC sinusoidal output
- 90 minute operation
- UL Listing

4C Option Wiring Diagram

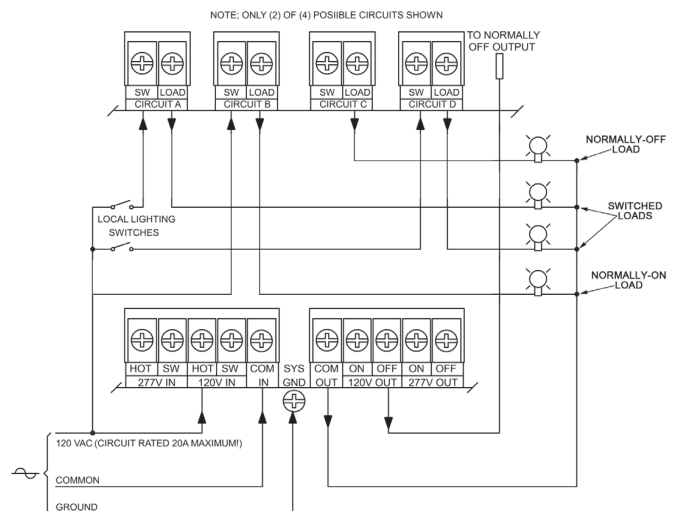

4C Option Line Voltage Switching

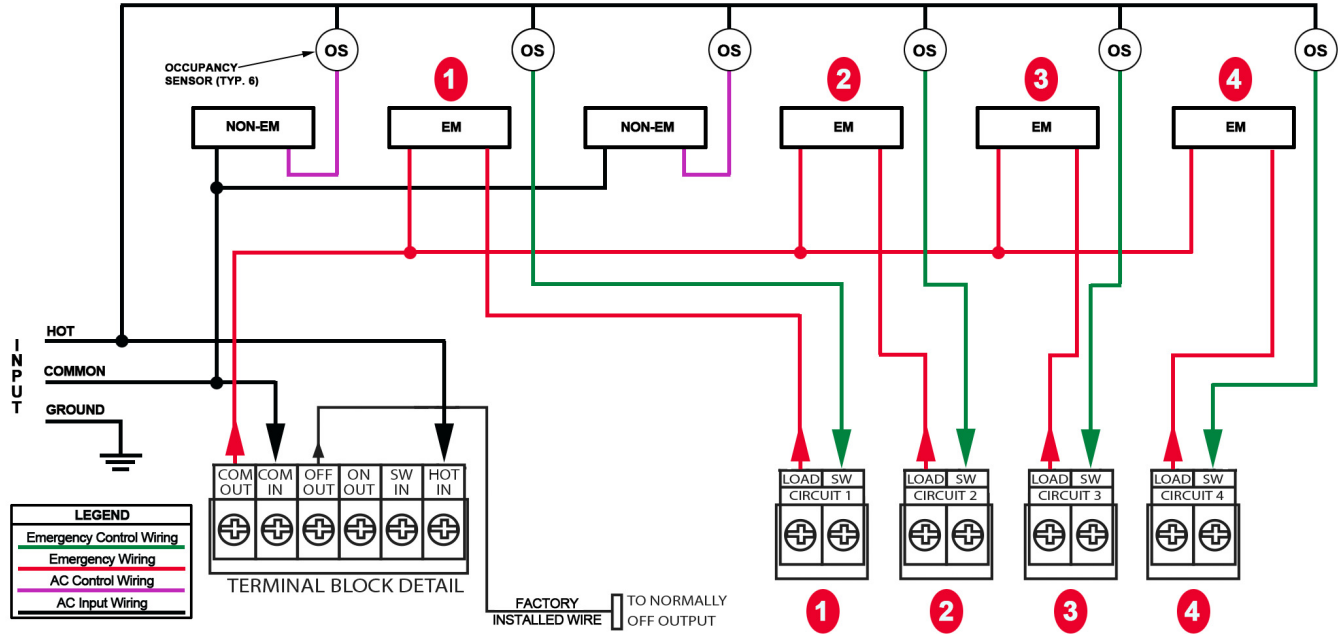

4C Option Schematic

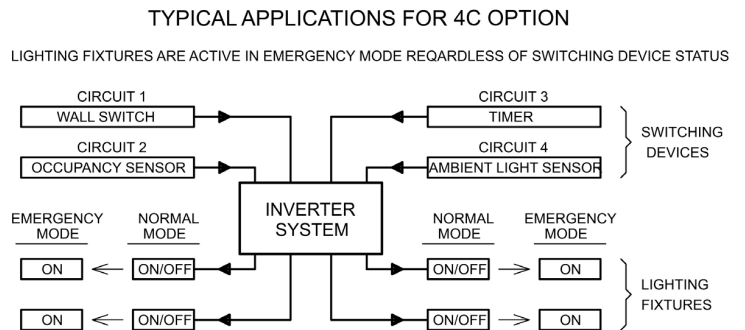
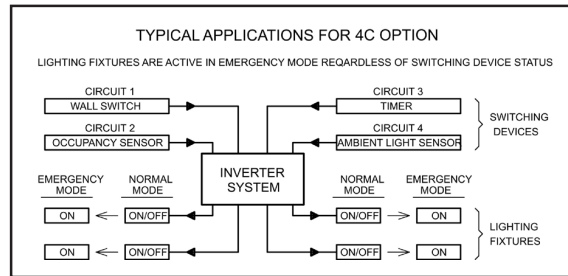
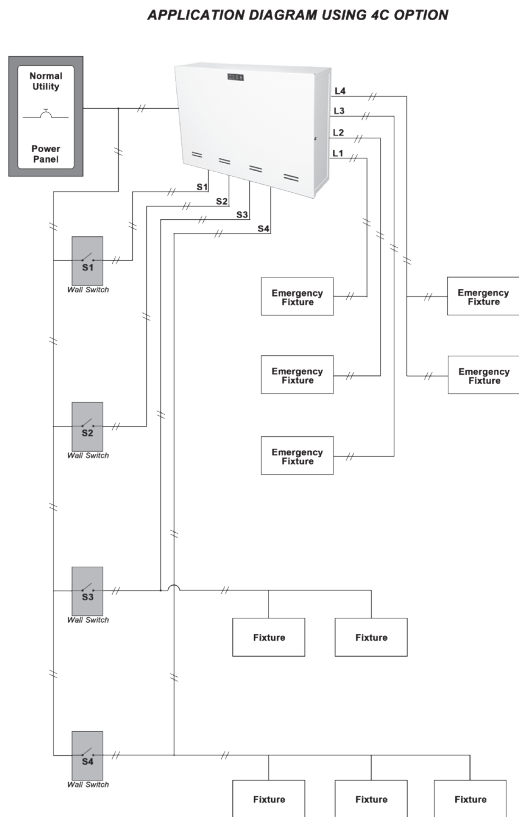

Mini and Midsize Inverter Emergency Power Systems AO and 4AO Option

Provides adjusted power output to dimmable LED Lighting loads during emergency mode operation independent of dimmer control switch position

Features

- For use with 0 to 10 volt dimmable LED lighting fixtures
- AO Option for use with Mini model inverters provides two user-adjustable emergency output circuits
- 4AO Option for use with Midsize model inverters provides four user-adjustable emergency output circuits
- Delivers 25%, 50%, 75% or 100% of full illumination levels to selected LED fixtures during emergency mode operation regardless of local dimmer control switch position
- Works with all standard 0 to 10 volt dimmer controls
- Reduced emergency illumination levels means fewer total emergency inverter units required on jobs
- The AO Option for Mini Series inverters eliminates the need for bypass devices on 0 to 10 volt dimmer controlled fixtures
- The 4AO Option for Midsize Series inverters eliminates the need for up to four bypass devices on 0 to 10 volt dimmer controlled fixtures
- All wiring is done within the Mini or Midsize inverter housing, no need for additional j-boxes
- Allows normally-on, normally-off, combination and switched wiring of connected loads
- System may be remotely mounted up to 1,000 feet
- The AO Option is available on Mini inverter models with 55 to 220 watt capacity ratings
- The 4AO Option is available on Midsize inverter models with 375 to 600 watt capacity ratings

AO Option Operation

The AO Option is designed for use with the Mini Series of inverter power systems. The option will bypass one 0 to 10 volt local dimmer switch as well as allow user-programmable setting of emergency output lighting levels. Two load terminals as well as two dip-switch sets for independent output settings are provided to allow 25%, 50%, 75% or 100% of nominal illumination output during power outages. This outstanding level of control allows for fewer Mini Inverter power systems to be required in typical applications.

4AO Option Operation

The 4AO Option is designed for use with the Midsize Series of inverter power systems. The option can bypass up to four 0 to 10 volt local dimmer switches as well as allow user-programmable setting of emergency output lighting levels. Four load terminals as well as four dip-switch sets for independent output settings are provided to allow 25%, 50%, 75% or 100% of nominal illumination output during power outages. This outstanding level of control allows for fewer Mini Inverter power systems to be required in typical applications.

Mini Inverters



Midsize Inverters



All Mini and Midsize Series inverters offer:

- Universal 120/277VAC sinusoidal output
- 90 minute operation
- UL Listing

AO/4AO Option Connectivity

The AO and 4AO option's emergency output circuits may be used to power dimmable LED lighting loads up to the maximum output capacity of the Mini and Midsize Inverter system. Additionally, the override circuits allow the user to select the power level the connected load will be operated at in emergency mode. Each override circuit is controlled by DIP switches which determine the emergency output power level. Emergency output can be set for 25%, 50%, 75% or 100% of maximum fixture illumination, independent of the local dimmer switch position. This level of flexibility provides a highly efficient use of the system output.

The outstanding features of the Mini and Midsize Inverter Series systems provide additional connectivity and flexibility features to the AO and 4AO options. The system's universal output allows for the power-ing of 120VAC and/or 277VAC loads and because the system's output is a clean, sinusoidal waveform, load compatibility issues are never a problem. Additionally, provisions are provided so that emergency loads can be configured for normally-on, normally-off, combination or switched operation.

AO Option Wiring

DIMMING OPTION, 120V OPERATION

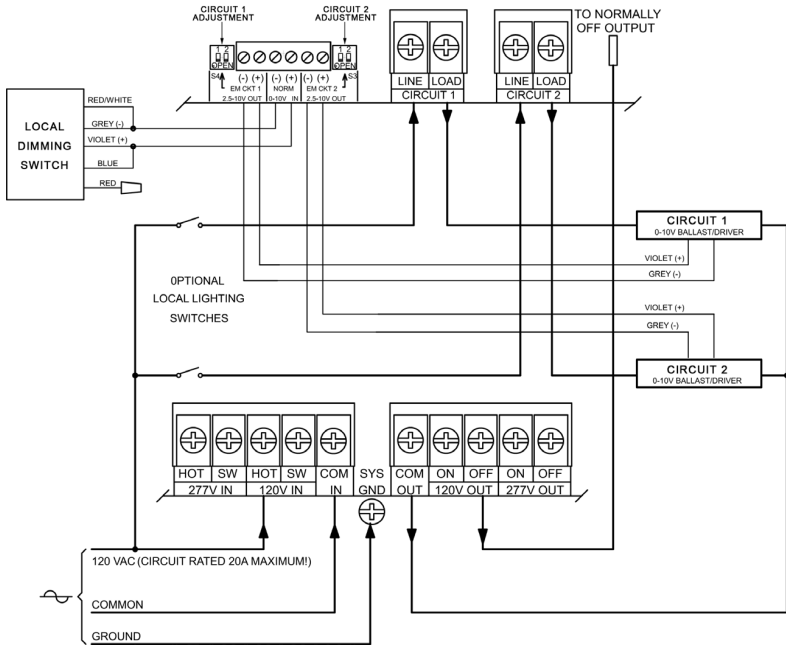

DIMMING OPTION PROGRAMMING TABLE

S1,2-1	S1,2-2	VOUT 1, VOUT 2
OPEN (OFF)	OPEN (OFF)	10.0V
OPEN (OFF)	CLOSED (ON)	7.50V
CLOSED (ON)	OPEN (OFF)	5.00V
CLOSED (ON)	CLOSED (ON)	2.50V

DIMMING OPTION CONTROL WIRING

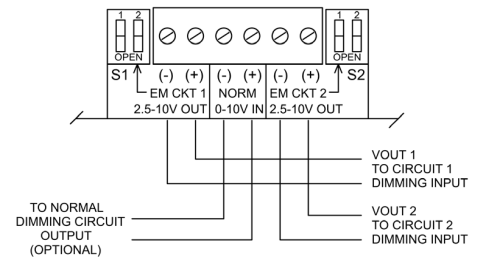

4AO Option Wiring

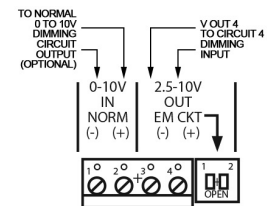
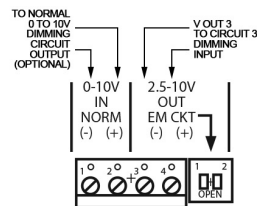
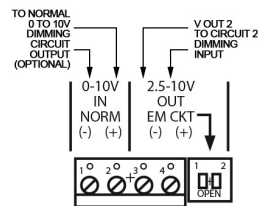
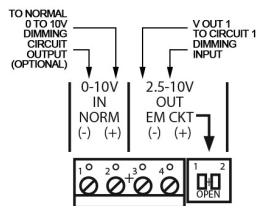
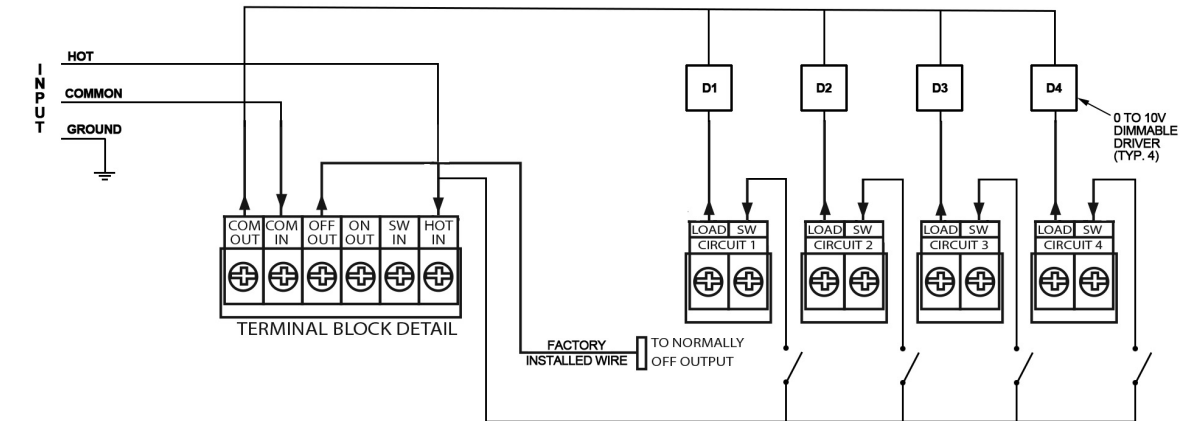

DIMMING OPTION PROGRAMMING TABLE

S1,2-1	S1,2-2	VOUT 1, VOUT 2
OPEN (OFF)	OPEN (OFF)	10.0V
OPEN (OFF)	CLOSED (ON)	7.50V
CLOSED (ON)	OPEN (OFF)	5.00V
CLOSED (ON)	CLOSED (ON)	2.50V

DIMMING OPTION CONTROL WIRING

Remote Test Switch



APPLICATION

- RTS provides remote testing capability for Mini Series Inverter, unit equipment and exit signs. Not compatible with emergency ballasts.

ELECTRICAL

- Field selectable 120 voltage or 277 voltage.
- Power "ON" LED indicator light and push-to-test switch for mandated code compliance testing.

MOUNTING

- Remote Test Switch can be mounted to any standard switch box.
- Suitable for wall or ceiling mount.

CONSTRUCTION

- Injection-molded, engineering grade, V-0 flame retardant mounting plate in white finish.

WARRANTY / LISTING

- Five year warranty.
- Meets UL924, NFPA 101 Life Safety Code, NEC, OSHA, Local and State Codes.

DIMENSIONS

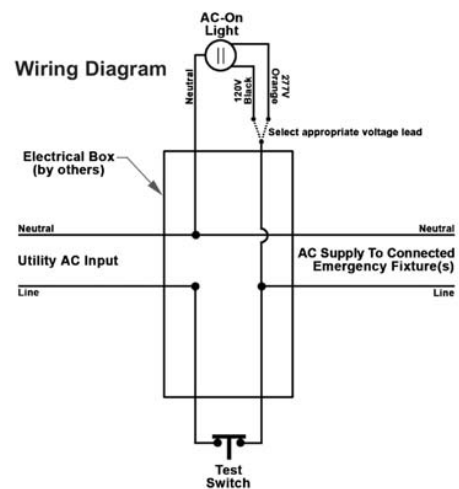
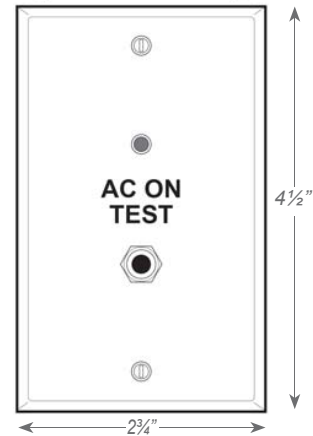

ORDERING INFORMATION

Sample Part Number: RTS

MODEL

RTS